

	TOP 38
WNF	117,81 m ²
Terrasse	15,37 m ²
Garten	34,02 m ²
	TOP 39
WNF	115,69 m ²
Terrasse	24,96 m ²
Garten	34,37 m ²
	TOP 40
WNF	96,10 m ²
Terrasse	15,08 m ²
Garten	32,96 m ²
	TOP 41
WNF	69,31 m ²
Terrasse	10,39 m ²
Garten	40,89 m ²

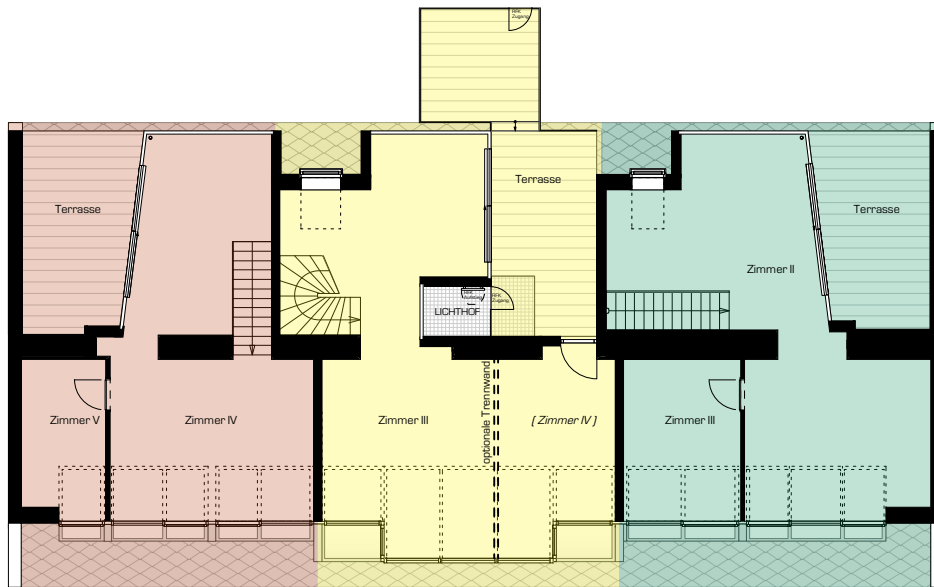

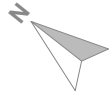

■	TOP 38
WNF	117,81 m ²
Terrasse	15,37 m ²
Garten	34,02 m ²
■	TOP 39
WNF	115,69 m ²
Terrasse	24,96 m ²
Garten	34,37 m ²
■	TOP 40
WNF	96,10 m ²
Terrasse	15,08 m ²
Garten	32,96 m ²
■	TOP 41
WNF	69,31 m ²
Terrasse	10,39 m ²
Garten	40,89 m ²



Systemschnitte

DG1, DG2

Engerthstrasse 149

1020 Wien

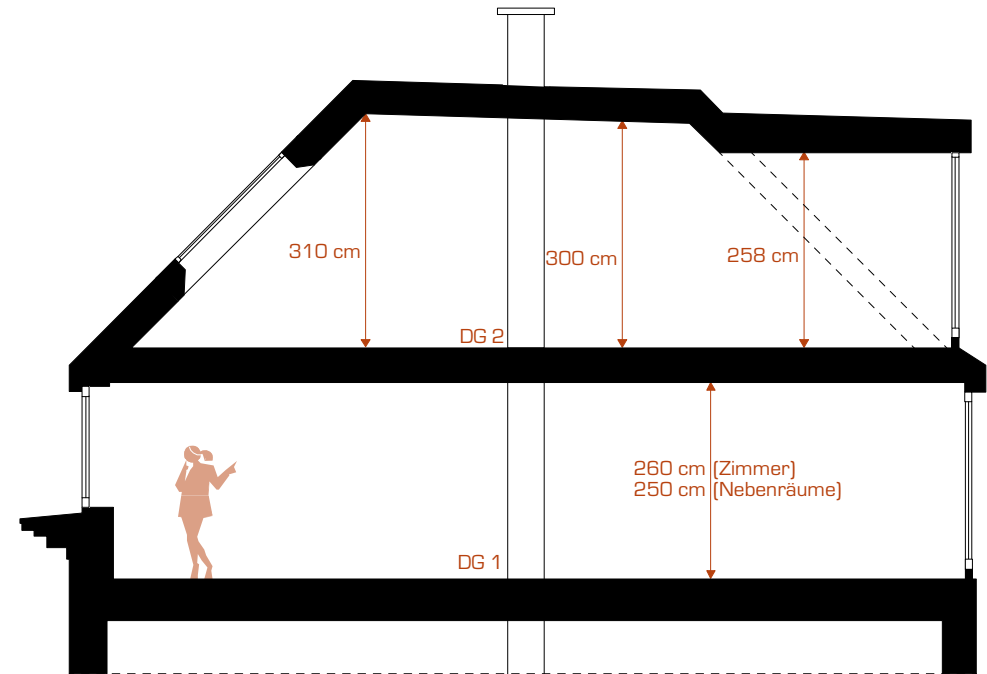
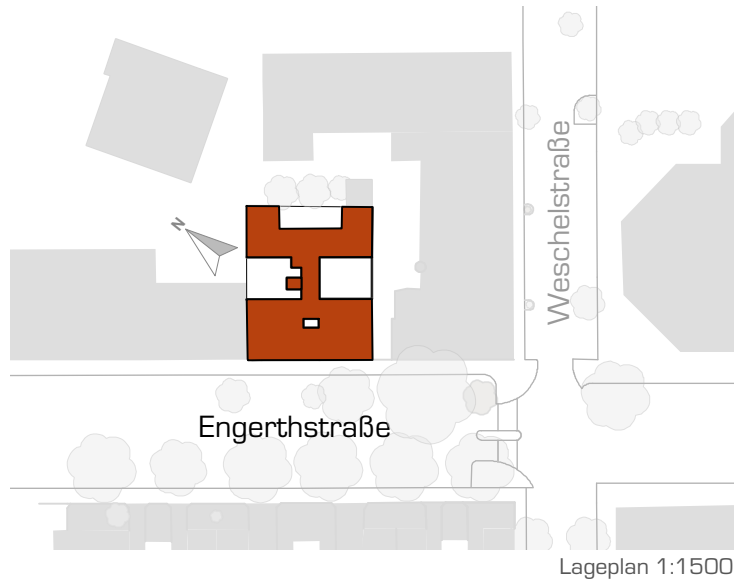

Schnitt 1

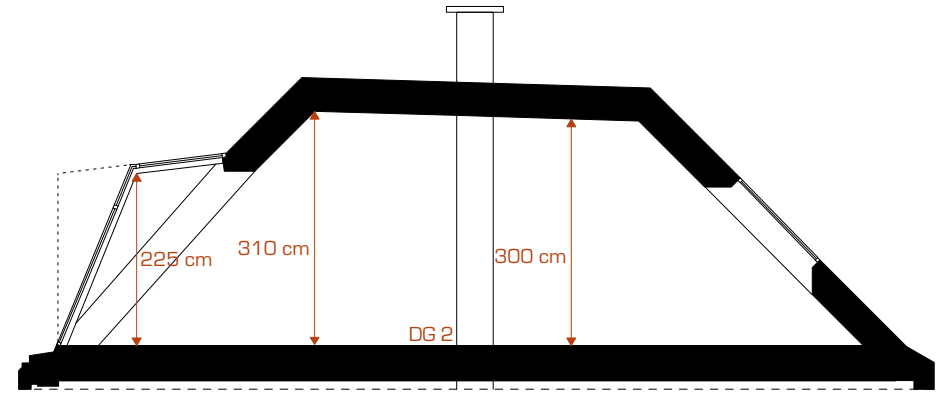
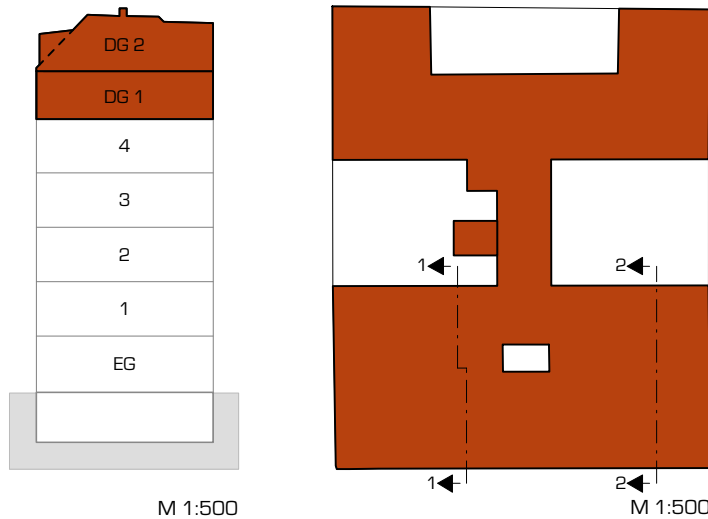

Schnitt 2

Planstand
19.02.2019

