

TOP 29
 WNF 84,54 m²
 Terrasse 11,66 m²

TOP 30
 WNF 120,15 m²
 Terrasse 22,55 m²

TOP 31
 WNF 135,42 m²
 Terrasse 36,36 m²

TOP 32
 WNF 134,51 m²
 Terrasse 16,85 m²

TOP 33
 WNF 87,11 m²
 Terrasse 8,38 m²

TOP 34
 WNF 79,37 m²
 Terrasse 46,34 m²

TOP 35
 WNF 90,59 m²
 Terrasse 51,42 m²



Planstand
 22.09.2020

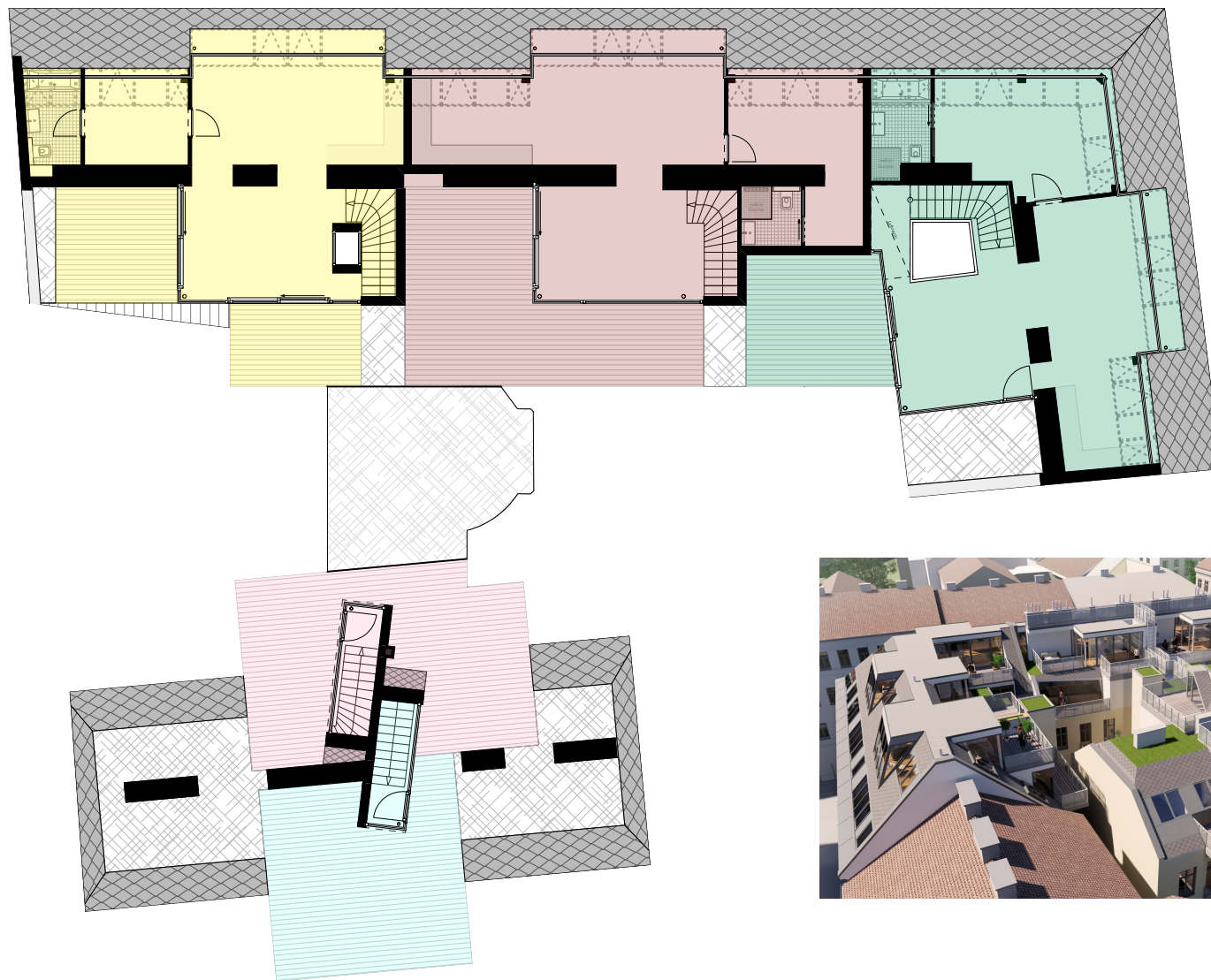

TOP 29
 WNF 84,54 m²
 Terrasse 11,66 m²

TOP 30
 WNF 120,15 m²
 Terrasse 22,55 m²

TOP 31
 WNF 135,42 m²
 Terrasse 36,36 m²

TOP 32
 WNF 134,51 m²
 Terrasse 16,85 m²

TOP 33
 WNF 87,11 m²
 Terrasse 8,38 m²

TOP 34
 WNF 79,37 m²
 Terrasse 46,34 m²

TOP 35
 WNF 90,59 m²
 Terrasse 51,42 m²

Planstand
 22.09.2020

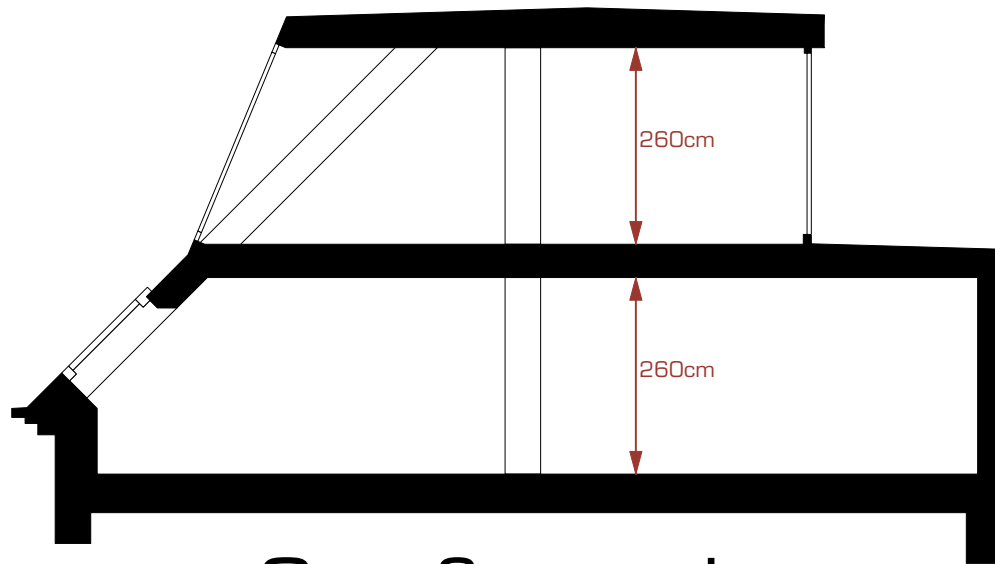

Straßentrakt

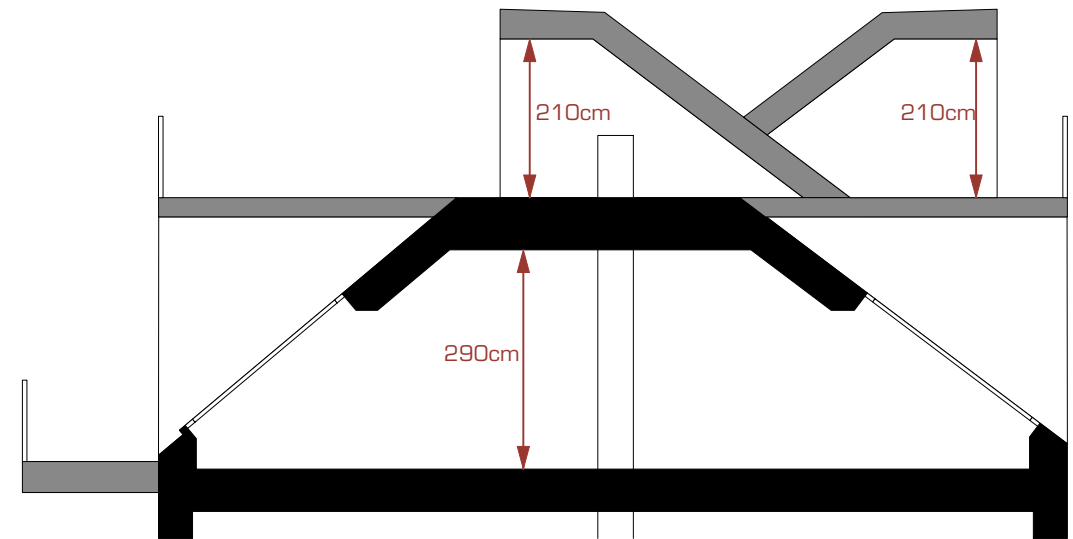

Hoftrakt

Planstand
22.09.2020